

**TITLE: SPECIFICATION CONTROL DRAWING**

**PART IDENTIFIER:** AN7-XNXF

X = TEMPERATURE COEFFICIENT OF ATTENUATION.  $1 \times 10^{-3}$  DB/DB/°C.  
 N = ATTENUATION SHIFT NEGATIVE.  
 X = DB VALUE SEE TABLE BELOW.

SHIFT (NEG)	DB VALUE	FREQUENCY RANGE
-0.003		DC – 6 GHZ
-0.004		
-0.005		
-0.006		
-0.007		
-0.009	3, 4	

\*CONSULT FACTORY FOR ADDITIONAL VALUES.

**DESCRIPTION:** TEMPERATURE VARIABLE CHIP ATTENUATOR. (ROHS COMPLIANT)

**ASSEMBLY DWG:** 1902114

**1.0 SPECIFICATIONS:**

1.1 ELECTRICAL:

- 1.1.1 IMPEDANCE: 50 OHMS NOMINAL.
- 1.1.2 OPERATING FREQUENCY RANGE: SEE TABLE ABOVE.
- 1.1.3 ATTENUATION VALUES AVAILABLE: SEE TABLE ABOVE.
- 1.1.4 ATTENUATION ACCURACY AT 25°C: ±0.5DB @ 1 GHZ.
- 1.1.5 VSWR: 1.30:1 MAX. @ 1GHZ.
- 1.1.6 INPUT POWER: 100 MILLIWATTS CW.
  - 1.1.6.1 FULL RATED POWER TO 125°C, DERATED LINEARLY TO 0 WATTS AT 150°C.
- 1.1.7 TEMPERATURE COEFFICIENT OVER OPERATING TEMPERATURE RANGE:  
SEE TABLE ABOVE, TEMPERATURE COEFFICIENT TOLERANCE: ±0.001 DB/DB/°C.

1.2 MECHANICAL:

- 1.2.1 OUTLINE DWG: SEE SHEET 2.
- 1.2.2 WORKMANSHIP: PER MIL-PRF-55342.

1.3 ENVIRONMENTAL:

- 1.3.1 OPERATING TEMPERATURE RANGE: -55°C TO +150°C

**2.0 UNIT MARKING:** ORIENTATION "T"

LEGIBILITY AND PERMANENCY PER MIL-STD-130

**3.0 QUALITY ASSURANCE:**

- 3.1 SAMPLE INSPECT PER ANSI/ASQC Z1.4 GENERAL INSPECTION, LEVEL II, AQL = 1.0.
  - 3.1.1 VISUAL AND MECHANICAL EXAMINATION FOR CONFORMANCE TO OUTLINE DRAWING REQUIREMENTS.
- 3.2 SAMPLE INSPECTION (DESTRUCTIVE TESTING).
  - 3.2.1 SELECT THREE (3) UNITS FROM LOT AND MEASURE DCA EVERY 20°C OVER THE TEMPERATURE RANGE -55°C TO +125°C.
    - 3.2.1.1 CALCULATE, USING LINEAR REGRESSION, THE SLOPE OF THE CURVE.
    - 3.2.1.2 CALCULATE TCA USING THE FOLLOWING FORMULA:  

$$TCA = \frac{SLOPE}{ATTENUATION @ 25^{\circ}C}$$
    - 3.2.1.3 ACCEPTANCE LIMITS: PER 1.1.7.
- 3.3 INSPECTION IN ACCORDANCE WITH QA0006 AND FORM0357 FOR COMMERCIAL GRADE PRODUCT.
- 3.4 TEST DATA REQUIREMENTS:
  - 3.4.1 NO TEST DATA REQUIRED FOR CUSTOMER.
  - 3.4.2 DATA RETENTION - 24 MONTHS.

**4.0 PACKAGING:** STANDARD TAPE AND REEL PACK PER MC0023.

EMC TECHNOLOGY 8851 SW OLD KANSAS AVE. STUART, FL 34997	<b>CAGE CODE # 24602</b>		<b>DWG #</b>	1011505000
	<b>CHANGE NOTICE</b>	EN 09-E0285	<b>REV LVL</b>	B
			<b>SHEET</b>	1 OF 2

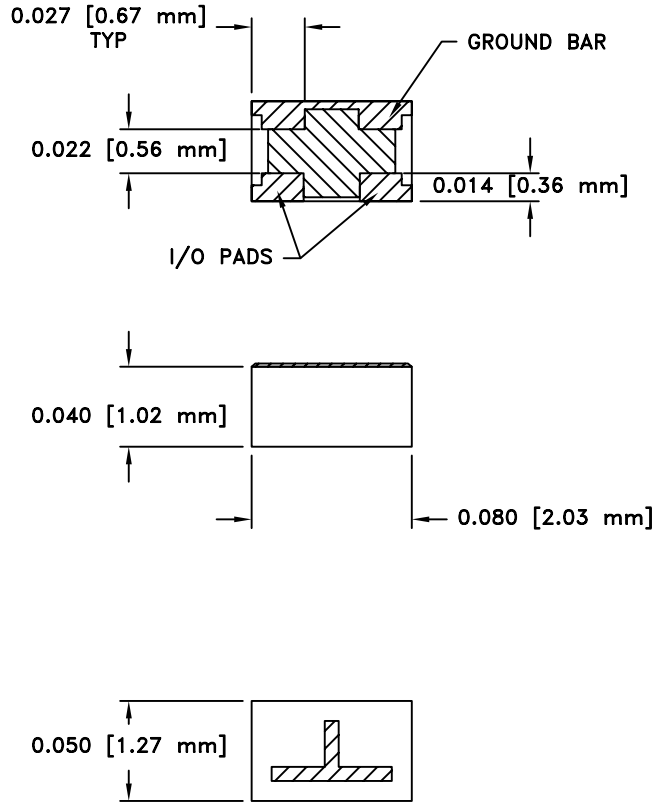

**MECHANICAL SPECIFICATIONS:**

SUBSTRATE:  
 MATERIAL - ALUMINA 96%, MIL-I-10.  
 TERMINAL:  
 MATERIAL - THICK FILM, RoHS COMPLIANT  
 RESISTIVE ELEMENT:  
 MATERIAL - THICK FILM.

METRIC EQUIVALENTS GIVEN IN [mm]  
 FOR REFERENCE INFORMATION ONLY

**POWER RATING AND DERATING**

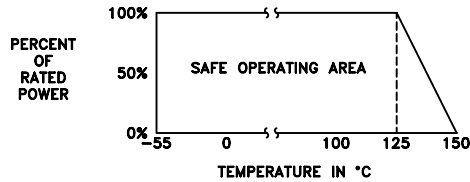

8851 SW OLD KANSAS AVE  
 STUART, FL 34997  
 PHONE NO. (772)286-9300  
 FAX NO. (772)283-5286

UNLESS OTHERWISE SPECIFIED DIMENSIONS ARE IN INCHES

**TOLERANCES**

FRACT	---
ANG	---
XX	---
XXX	±0.005
XXXX	---

THESE DRAWINGS AND SPECIFICATIONS ARE THE PROPERTY OF EMC TECHNOLOGY INC AND SHALL NOT BE DUPLICATED OR USED AS BASIS FOR THE MANUFACTURE OR SALE OF PARTS OR DEVICES WITHOUT PERMISSION.

CAGE CODE	SCALE	DRAWN BY	CHECKED BY	APPROVED BY
24602	32:1	CRH 03/20/09		
REV	CHANGE NOTICE	DRAWING NO	SHEET	
B	EN 09-E0285	1011505000	2 OF 2	