



Features

- Single Positive Voltage Supply (5V to 16.5V)
- Adjustable Drain Voltage 3V to 15V
- Adjustable Drain Current up to 500mA
- Internal Negative Voltage Generator
- Active Bias Current Regulation
- Stable Bias Current Over Temperature and Process Variation and Aging
- Short Circuit Protection (Power Foldback)
- Adjustable Over/Under-Current Alarm
- Adjustable Low Vdd Voltage Alarm
- Automated Power-up Sequencing
- Enable Input for Active Bias Control
- Trigger-out Output for Daisy Chain Power-Up and Power-Down Sequencing

Typical Applications

- Cellular Base Station
- Wireless Infrastructure Equipment
- Microwave Radio & VSAT
- Military & Space
- Test Instrumentation

Functional Diagram

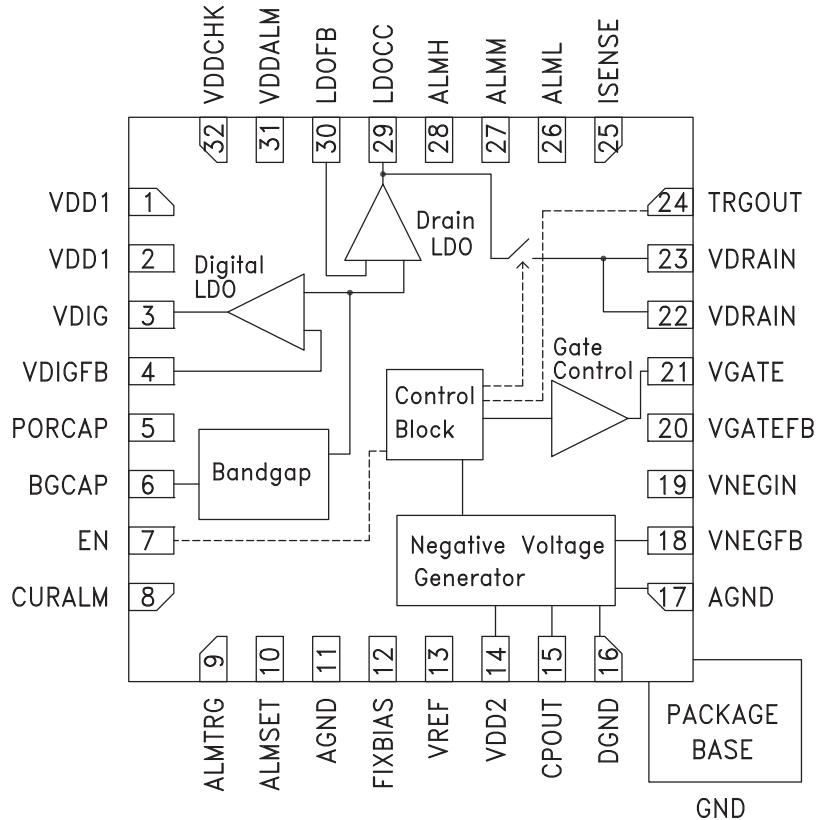

General Description

HMC920LP5E is an active bias controller which generates a regulated Drain voltage and actively adjusts the gate voltage of an external amplifier to achieve constant bias current. It can be used to bias any enhancement and depletion type amplifiers operating in Class-A regime with Drain voltages (VDRAIN) from 3V to 15V and drain currents (IDRAIN) up to 500mA, offering a complete biasing solution.

HMC920LP5E achieves excellent bias stability over supply, temperature and process variations, and eliminates the required calibration procedures used to prevent RF performance degradation due to such variations.

The HMC920LP5E is housed in an RoHS compliant 5x5 mm QFN leadless package with an exposed backside pad to improve thermal characteristics.

Electrical Specifications, $T_A = +25^\circ\text{C}$, $V_{dd1} = V_{dd2} = 15\text{V}$

Parameter	Symbol	Conditions	Min.	Typ.	Max.	Units
Supply Voltage	Vdd		5		16.5	V
Quiescent Current	IDD	Vdd = 5V	EN = Vdig	35		mA
			EN = GND	20		mA
		Vdd = 15V	EN = Vdig	35		mA
			EN = GND	20		mA
Negative Voltage Output	VNEG			-2.5	V	
Oscillator Frequency	FOSC			250	kHz	
Bandgap Reference	VBGC			2	V	
VDIG Feedback	VDIGFB			2.5	V	
LDOCC Feedback	LDOFB			2	V	
Enable Input Threshold	ENTHRS	Vinlow			1	V
		Vinhigh	1.4			V
ALMTRIG Input Threshold	ALMTRIG	Vinlow			1	V
		Vinhigh	1.4			V
Low Vdd Alarm Threshold	VddCHK			3.8	V	
VDRAIN Characteristics						
DRAIN Current Adjustment Range	IDRAIN		0		500	mA
DRAIN Current Change Over Supply Voltage	Δ IDRAINV	VDRAIN set to 6V, IDRAIN set to 100mA,		0.05		%/V
DRAIN Current Change Over Temperature				0.03		%/C
DRAIN Adjustment Range	VDRAIN		3		15	V
VDRAIN Change Over Supply Voltage	Δ VDRAIN	VDRAIN set to 6V, IDRAIN set to 100mA,		0.05		%/V
VDRAIN Change Over Temperature				0.008		%/C
VNEG Characteristics						
Negative Voltage Output	VNEG			-2.5		V
VNEG Current Sink	INEG		0		60	mA
VGATE Characteristics						
GATE Current Supply	IG		-4		4	mA
VGATE Low Level	VG_MIN			VNEG		V
VGATE High Level	VG_MAX			VNEG+4.5		V
VDIG Characteristics						
Adjustment Range	VDIG		3.5		5	V
VDIG Current Source	IDIG				30	mA

IDRAIN Regulation Accuracy vs. Vdd [1][2]

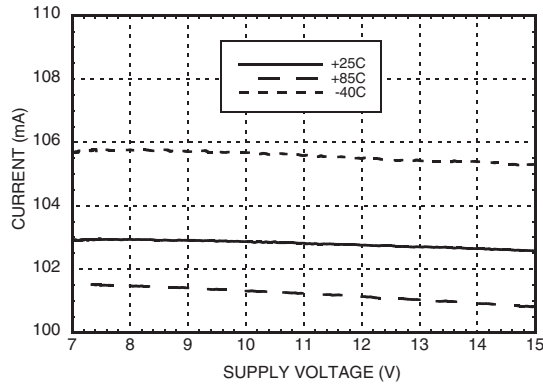

VDRAIN Line Regulation Over IDRAIN

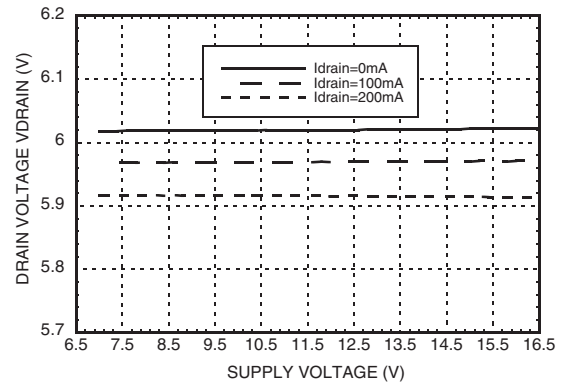

VDRAIN Line Regulation Over Temperature

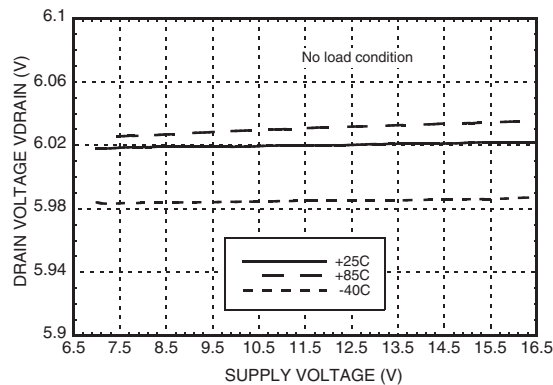

VDIG Line Regulation Over Temperature

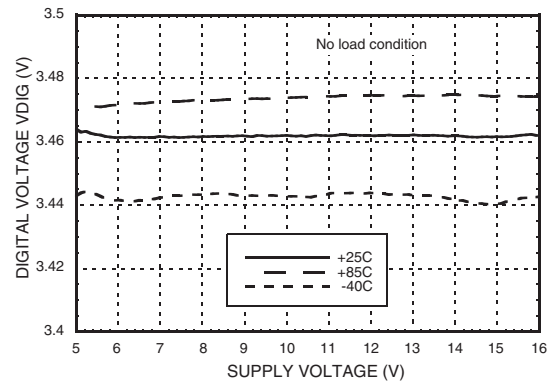

VNEG Line Regulation Over Temperature

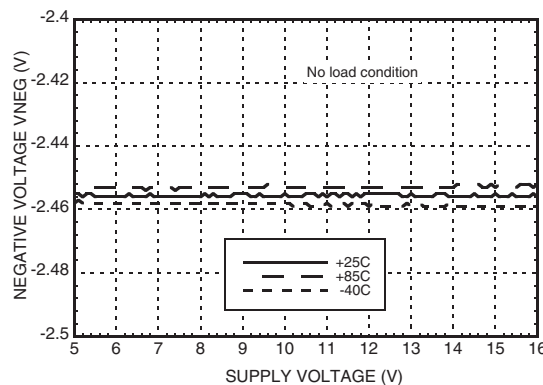

VDRAIN Load Regulation Over Vdd

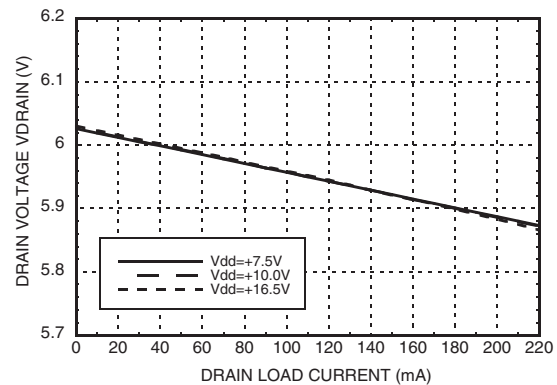

[1] IDRAIN is set to 110mA [2] HMC594LC3B is used as external amplifier



ACTIVE BIAS CONTROLLER

VDRAIN Load Regulation Over Temperature [1]

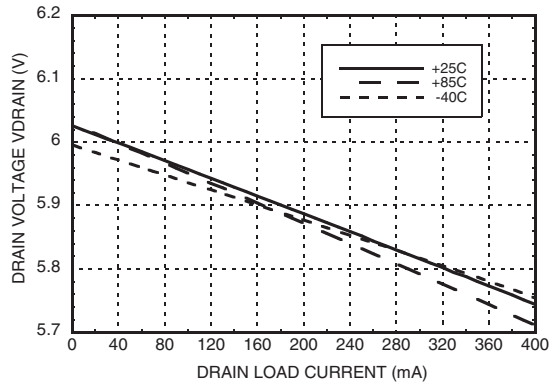

VDIG Load Regulation Over Temperature

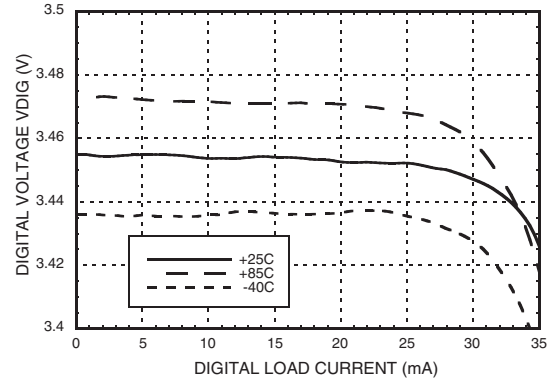

VNEG Load Regulation Over Temperature [2]

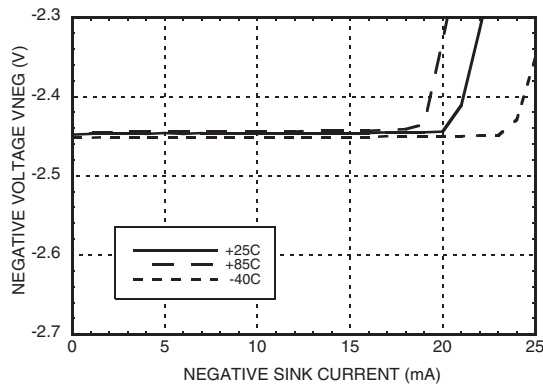

VNEG Load Regulation Over Temperature [3]

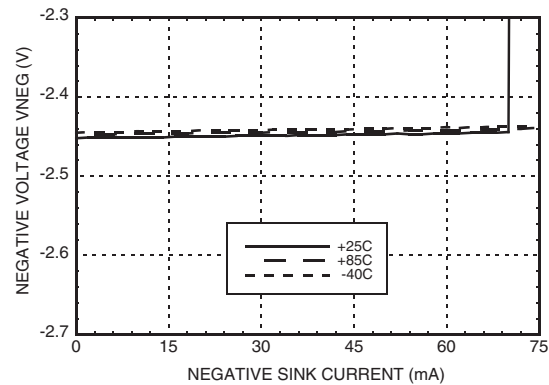

Enable Waveform

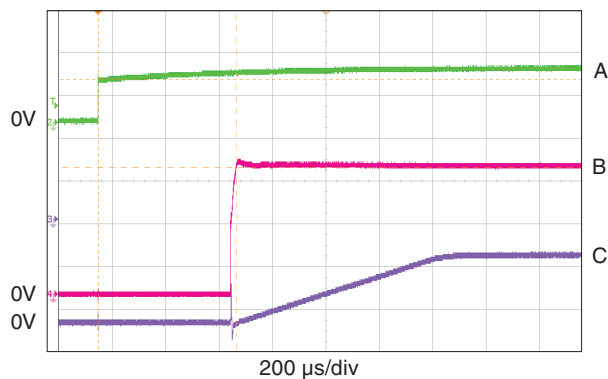

A	Enable Pin, 5 V/div	C	VGATE, 1 V/div
B	VDRAIN, 2 V/div		

Disable Waveform

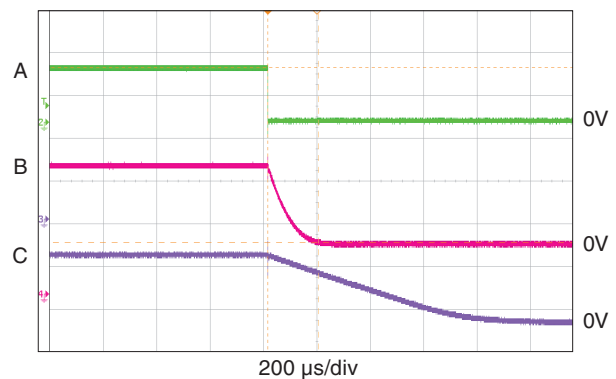

A	Enable Pin, 5 V/div	C	VGATE, 1 V/div
B	VDRAIN, 2 V/div		

[1] Vdd = 7.5V

[2] Vdd = 5V

[3] Vdd = 16.5V

VDRAIN Load Transient

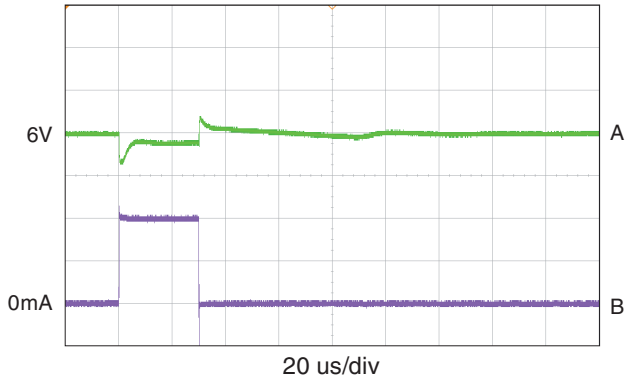

A	VDRAIN, 500 mV/div
B	IDRAIN, 100 mA/div

VDOCC Load Transient

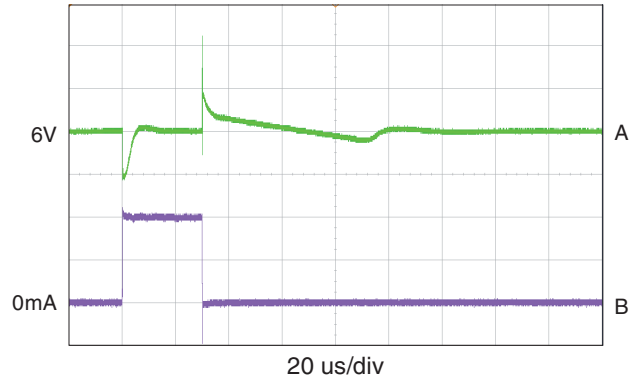

A	LDOCC, 200 mV/div
B	IDRAIN, 100 mA/div

VDIG Load Transient

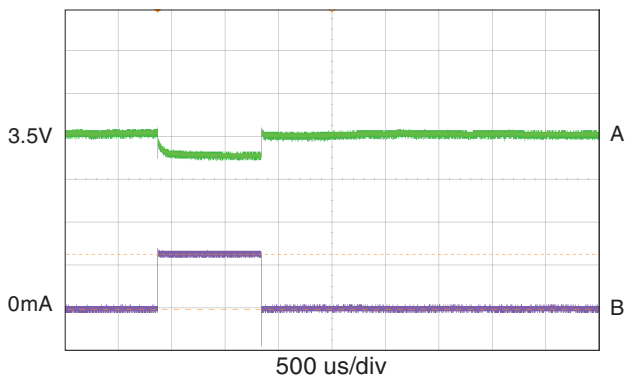

A	VDIG, 50 mV/div
B	IDIG, 20 mA/div

VNEG Load Transient

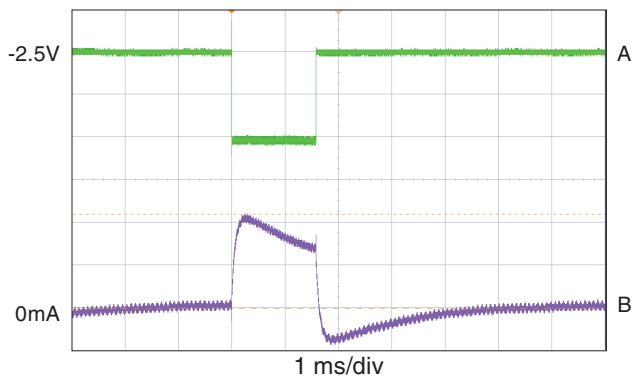

A	VNEG, 50 mV/div
B	INEG, 5 mA/div

Power Up Waveform

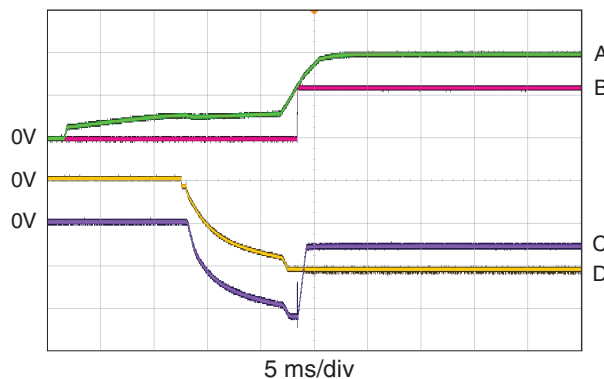

A	Vdd, 5V/div	C	VGATE, 1V/div
B	VDRAIN, 5V/div	D	VNEG, 1V/div

Power Down Waveform

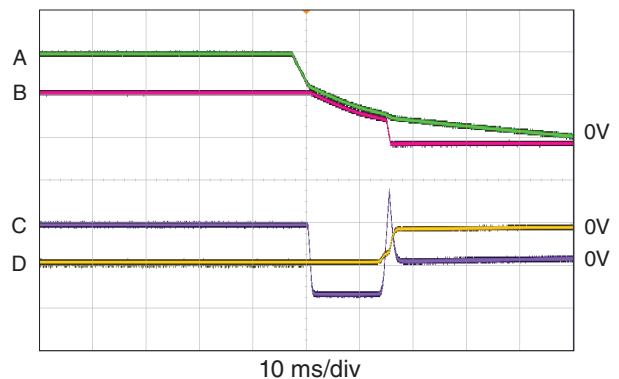

A	Vdd, 5V/div	C	VGATE, 1V/div
B	VDRAIN, 5V/div	D	VNEG, 1V/div

Absolute Maximum Ratings ^[1]

Vdd1, Vdd2 to GND	-0.3V to +16.5V
VDIG to GND	-0.3V to +5.5V
VDIGFB, PORCAP, BGCAP, EN, CURALM, ALMTRIG to GND	-0.3V to (VDIG + 0.3V)
ALMSET, ALMC1, ALMC2, REF to GND	-0.3V to (Vdd + 0.3V)
VNEGFB, VGATE, VDRAIN, ISENSE to GND	-0.3V to (Vdd + 0.3V)
VNEGIN to GND	-4V to (Vdd + 0.3V)
ALML, ALMM, ALMH, LDOCC, LDOFB to GND	-0.3V to (Vdd + 0.3V)
VGATEFB, TRGOUT, VddALM, VddCHK to GND	-0.3V to (VDIG + 0.3V)

CPGND to GND	-0.3V to +0.3V
Vdd1 to Vdd2	-0.3V to +0.3V
Junction Temperature	125 °C
Continuous P _{diss} (T = 85 °C) (Derate 256.67 mW/°C above 85 °C)	10.27 Watts
Thermal Resistance (R _{TH}) (Junction to package bottom)	3.9 °C/W
Storage Temperature	-65 to +150 °C
Operating Temperature	-40 to +85 °C
ESD Sensitivity (HBM)	Class 1C

Note that there are two different voltage domains on HMC920LP5E; a high voltage domain Vdd, and a low voltage domain VDIG. Take necessary precautions not to violate ABS MAX ratings of each subdomains.



**ELECTROSTATIC SENSITIVE DEVICE
OBSERVE HANDLING PRECAUTIONS**

Outline Drawing

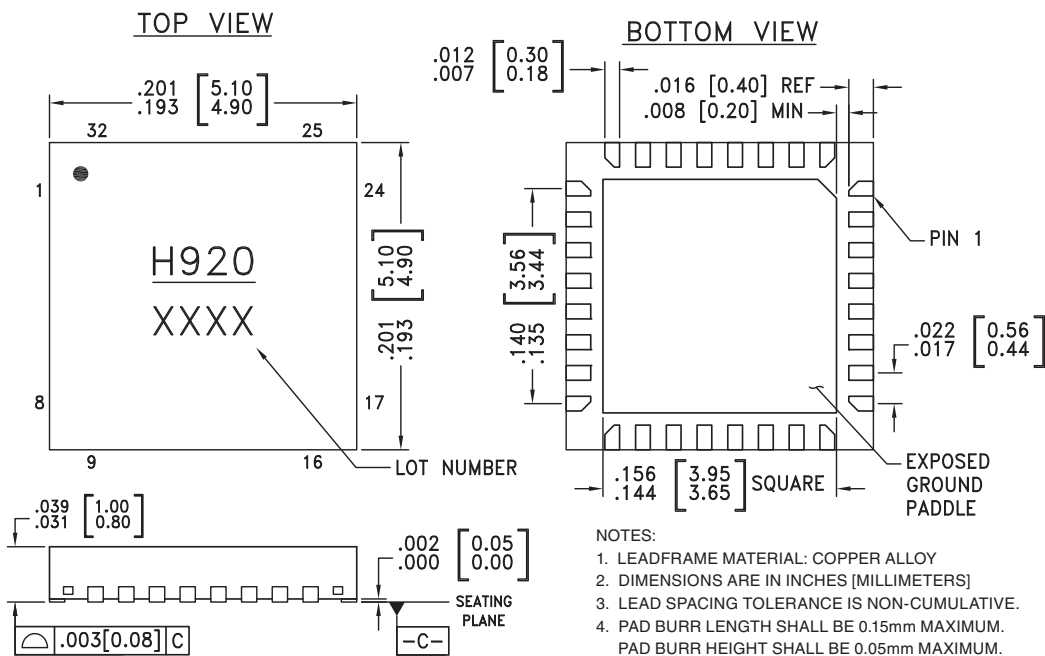

NOTES:

1. LEADFRAME MATERIAL: COPPER ALLOY
2. DIMENSIONS ARE IN INCHES [MILLIMETERS]
3. LEAD SPACING TOLERANCE IS NON-CUMULATIVE.
4. PAD BURR LENGTH SHALL BE 0.15mm MAXIMUM. PAD BURR HEIGHT SHALL BE 0.05mm MAXIMUM.
5. PACKAGE WARP SHALL NOT EXCEED 0.05mm.
6. ALL GROUND LEADS AND GROUND PADDLE MUST BE SOLDERED TO PCB RF GROUND.
7. REFER TO HITTITE APPLICATION NOTE FOR SUGGESTED LAND PATTERN.

Package Information

Part Number	Package Body Material	Lead Finish	MSL Rating	Package Marking ^[1]
HMC920LP5E	RoHS-compliant Low Stress Injection Molded Plastic	100% matte Sn	MSL1 ^[2]	H920 XXXX

[1] 4-Digit lot number XXXX

[2] Max peak reflow temperature of 260 °C

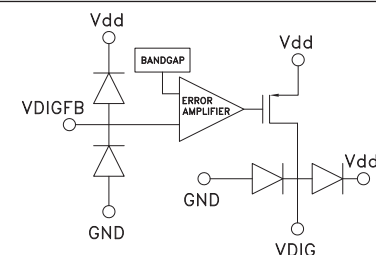
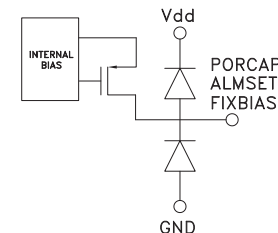
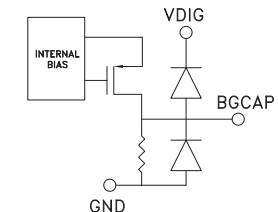
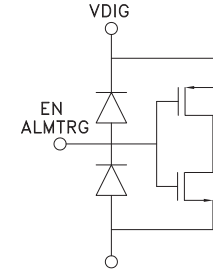
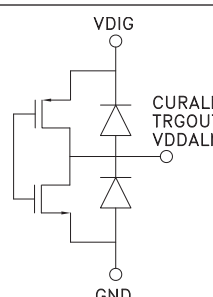

Pin Descriptions

Pin Number	Function	Description	Interface Schematic
1, 2	Vdd1	Bias supply Pins. Connect supply voltage to all these pins with appropriate filtering	
3	VDIG	3.5V LDO output for internal use. Output capability <30mA. Is not recommended for external use.	
4	VDIGFB	Feedback node for VDIG LDO. Should be left floating for regular operation.	
5	PORCAP	External capacitor for power-on-reset signal. 47pF to GND is needed. If longer POR duration is needed, can be increased.	
10	ALMSET	A resistor to ground is needed. The value of the resistor determines the alarm delay duration. The value of the resistor can be chosen between 10K and 10M.	
12	FIXBIAS	A high precision (e.g. 0.5%, ±25 ppm TCR) 10K resistor to ground is needed. Variance in the resistance will cause deviation in the bias current.	
6	BGCAP	External capacitor of bandgap output. Connect a 10nF low ESR ceramic capacitor to GND.	
7	EN	Enable pin. System is enabled when Ven is HIGH (3.5V). IF left floating, Ven defaults to HIGH (enabled).	
9	ALMTRG	Dummy alarm trigger signal to create test alarm when taken HIGH (3.5V). Defaults to LOW (GND) when left floating.	
8	CURALM	Over/under current alarm. Active LOW (GND).	
24	TRGOUT	Trigger out signal. Generates a HIGH (3.5V) signal when the active bias system stabilizes. This signal can be used to trigger next device (ENABLE) if more than one HMC920LP5E is used in a daisy chain.	
31	VddALM	Generates an active LOW signal if Vdd1 drops below 3.5V.	

Pin Descriptions (Continued)

Pin Number	Function	Description	Interface Schematic
13	VREF	1.5V reference voltage. 100pF capacitor to GND is needed to decrease noise.	
14	Vdd2	Bias supply for negative voltage generator. Connect supply voltage with appropriate filtering.	
15	CPOUT	Negative voltage generator charge pump output. Negative voltage generator needs a flying capacitor, a reservoir capacitor and two diodes to operate. Please refer to the application schematic for more info.	
16	DGND	Digital ground domain (DGND).	
11, 17	AGND	Analog ground domain (GND).	
18	VNEGFB	Feedback (Control) pin for Negative Voltage Generator Charge Pump. Float to activate the negative voltage generator / Sort to GND to disable the negative voltage generator.	
19	VNEGIN	Negative input to the chip. Should be supplied with CPOUT when negative voltage generator is enabled, or connect to external VSS when negative voltage generator is enabled. For detailed usage please refer to the "Negative Voltage Generator" section.	
20	VGATEFB	Control pin for VGATEFB. Float VGATEFB when a depletion mode transistor is biased. Selects the mode of operation along with VNEGFB pin. For detailed usage please refer to the Table 1. Mode Selection.	

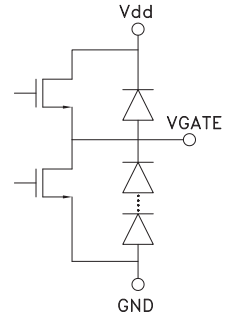
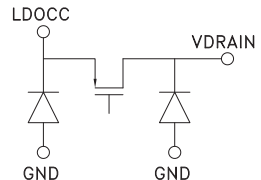
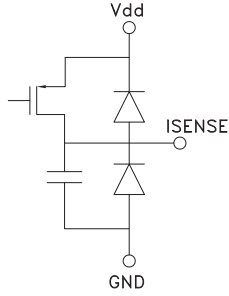
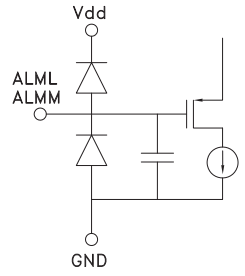
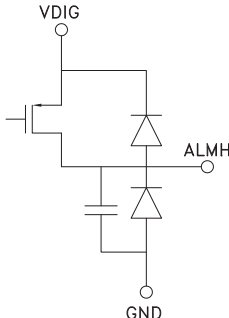

Pin Descriptions (Continued)

Pin Number	Function	Description	Interface Schematic
21	VGATE	Gate Control pin for external amplifier. Connect to the gate (base) of the external amplifier. In order to guarantee stability, a 10µF capacitor should be connected between the gate (base) terminal of the external amplifier and GND as close to the amplifier as possible.	
22, 23	VDRAIN	Drain voltage. Should be connected to the supply terminal of the external amplifier. A minimum 100 nF capacitor has to be placed close to the external amplifier to improve load regulation.	
25	ISENSE	To adjust the bias current of the external amplifier connect a resistor (Rsense) from ISENSE pin to GND. Use Eqn.4 to determine the required Rsense value.	
26	ALML	A high precision resistor (e.g. 0.5%, ±25 ppm TCR) to GND is needed. The value of the resistor sets the threshold value for under current alarm. Please refer to the "Over/Under Current Alarm" section for a detailed explanation.	
27	ALMM	A high precision resistor (e.g. 0.5%, ±25 ppm TCR) between ALML and ALMM is needed. The total external resistance from ALMM pin to GND should always be equal to 5 kΩ. Please refer to the "Over/Under Current Alarm" section for a detailed explanation.	
28	ALMH	A high precision resistor (e.g. 0.5%, ±25 ppm TCR) to ALMM pin is needed. The value of the resistor sets the threshold value for over current alarm. Please refer to the "Over/Under Current Alarm" section for a detailed explanation.	

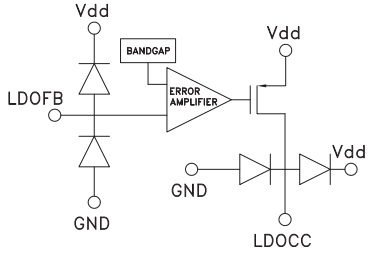
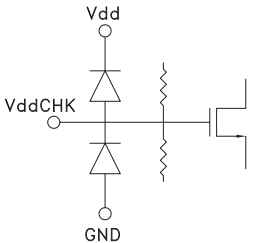

Pin Descriptions (Continued)

Pin Number	Function	Description	Interface Schematic
29	LDOCC	High voltage LDO output pin. To ensure stability, connect a 10 μ F capacitor with ESR>200 m Ω from LDOCC to GND. A tantalum capacitor is recommended to meet the ESR requirement.	
30	LDOFB	Feedback pin of the VDRAIN LDO. VDRAIN voltage is set by two resistors calculated with Eqn. 2.	
32	VddCHK	Should be left floating for regular operation.	
Paddle	GND PAD	Analog ground (AGND).	



ACTIVE BIAS CONTROLLER

Application Circuit

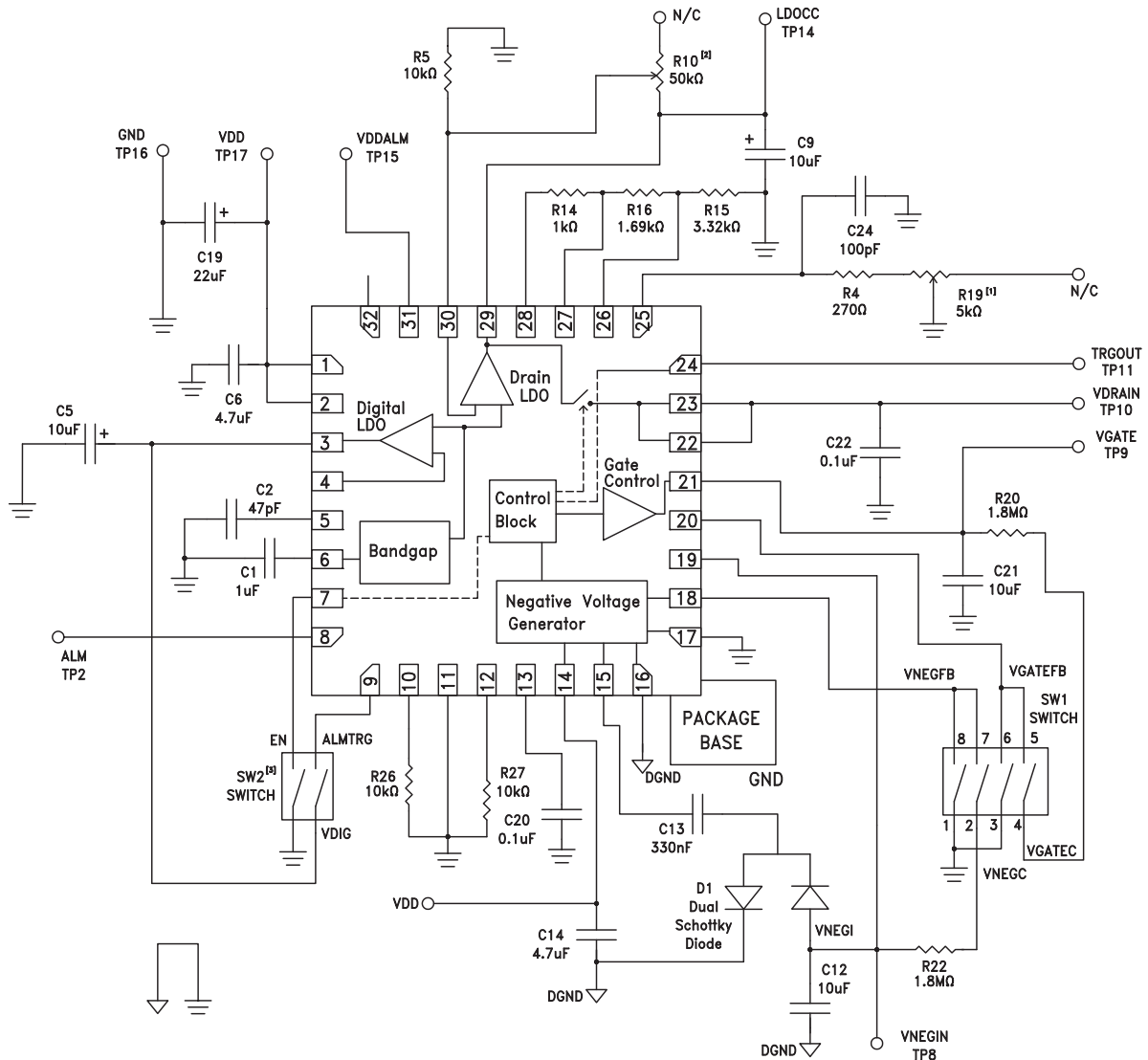

Notes:

- [1] A variable resistor is assembled on R19 slot to adjust bias current for evaluating various different amplifiers without soldering.
- [2] A variable resistor is assembled on R10 slot to adjust VDRAIN voltage for evaluating various different amplifiers without soldering.
- [3] SW2's function is to ENABLE and DISABLE the "Active Bias Control" function of the HMC920LP5E.

Evaluation PCB

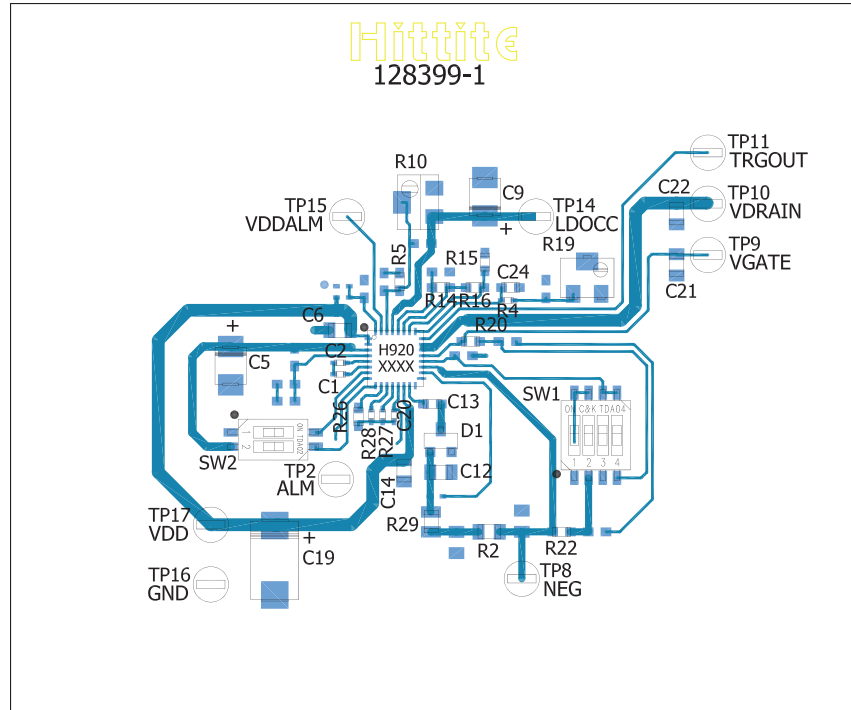

List of Materials for Evaluation PCB 130511 [1]

Item	Description
TP2, TP8 - TP11, TP14, TP15, TP17	1 μ F Capacitor, 0402 Pkg.
C2	47 pF Capacitor, 0402 Pkg.
C5, C9	10 μ F Capacitor, Case B Tantalum
C6, C14	4.7 μ F Capacitor, 0805 Pkg.
C12, C21	10 μ F Capacitor, 0805 Pkg.
C13	0.33 μ F Capacitor, 0603 Pkg.
C19	22 μ F Capacitor, Tantalum
C20	0.1 μ F Capacitor, 0402 Pkg.
C22	0.1 μ F Capacitor, 0805 Pkg.
C24	100 pF Capacitor, 0603 Pkg.
R2, R29	0 Ohm Resistor, 0805 Pkg.
R4	270 Ohm Resistor, 0402 Pkg.
R5, R26	10 kOhm Resistor, 0603 Pkg.
R10	50 kOhm Potentiometer
R14	1 kOhm Resistor, 0603 Pkg.
R15	3.32 kOhm Resistor, 0603 Pkg.
R16	1.69 kOhm Resistor, 0603 Pkg.
R19	5 kOhm Potentiometer
R20, R22	1.8M Ohm Resistor, 0603 Pkg.
R27	10 kOhm 0.5% \pm 25ppm/ $^{\circ}$ C Resistor, 0402 Pkg.

Item	Description
R28	0 Ohm Resistor, 0402 Pkg.
D1	Dual Schottky Diode
SW1	DIP 4 Position Half-Pitch Switch
SW2	DIP 2 Position Half-Pitch Switch
TP2,TP8-TP11,TP14,TP15,TP17	DC Test Point
U1	HMC920LP5E Active Bias Controller
PCB [2]	128399 Evaluation PCB

[1] Reference this number when ordering complete evaluation PCB

[2] Circuit Board Material: FR4

Careful PCB layout is critical to achieve stable and low noise operation. The negative voltage generator charge pump stage requires particular attention. To isolate the charge pump switching noise from the analog circuit blocks, create two separate ground planes dedicated to AGND and DGND connections. Connect AGND (pin#17) and DGND (pin#16) pins to the paddle at a single point under the package. Connect all the components connected to the charge pump (D1, C12 and C14 in the application circuit) to DGND plane, and connect rest of the external components to a low noise AGND.

Application Notes

Detailed Description

HMC920LP5E is an active bias controller which can be configured to provide the supply voltage and adjust the gate voltage of an external amplifier to achieve constant bias current. It can be used to bias both enhancement and depletion type amplifiers. The HMC920LP5E achieves excellent bias stability over supply and temperature variations. The gate control can both sink and source current (± 4 mA) to achieve constant bias current over input power variations.

The HMC920LP5E standard application circuit generates 3.5V digital supply voltage (VDIG) for internal use, and -2.5V negative voltage (VNEG) for depletion mode devices. If an external negative supply is already available or an enhancement mode device is targeted, the negative voltage generator can be disabled.

HMC920LP5E controls the bias current of the external amplifier with the gate control block. The current passing through the external amplifier is sampled and is used to control the VGATE voltage connected to the gate of the external amplifier to achieve constant quiescent bias through the external amplifier. This active bias control continuously adjusts the VGATE voltage to achieve constant bias current through the targeted amplifier independent of supply, temperature, process variations, and threshold shifts due to aging.

HMC920LP5E ensures safety of the external amplifier during turn on/off by adjusting the sequence of VDRAIN and VGATE outputs. The current passing through the external amplifier is monitored continuously. If a fault conditions arises (either under or over current) an alarm signal is generated (CURALM, active HIGH). A different alarm signal is generated (VddALM, active LOW) if the HMC920LP5E supply voltage drops below a certain threshold. Both supply voltage and current alarm signals provided in HMC920LP5E does not affect the operation of the controller. Both alarms has designed for monitoring purposes where a system level protection can be implemented with external control circuitry. The HMC920LP5E has power foldback and short circuit protection features.

The HMC920LP5E is a system on chip solution for the biasing needs of RF amplifiers and it has several functional blocks (see functional block diagram on the first page), to achieve the features summarized above. Refer to the section of the specific functional block for the detailed operation and adjustment descriptions.

Typical Application Diagram

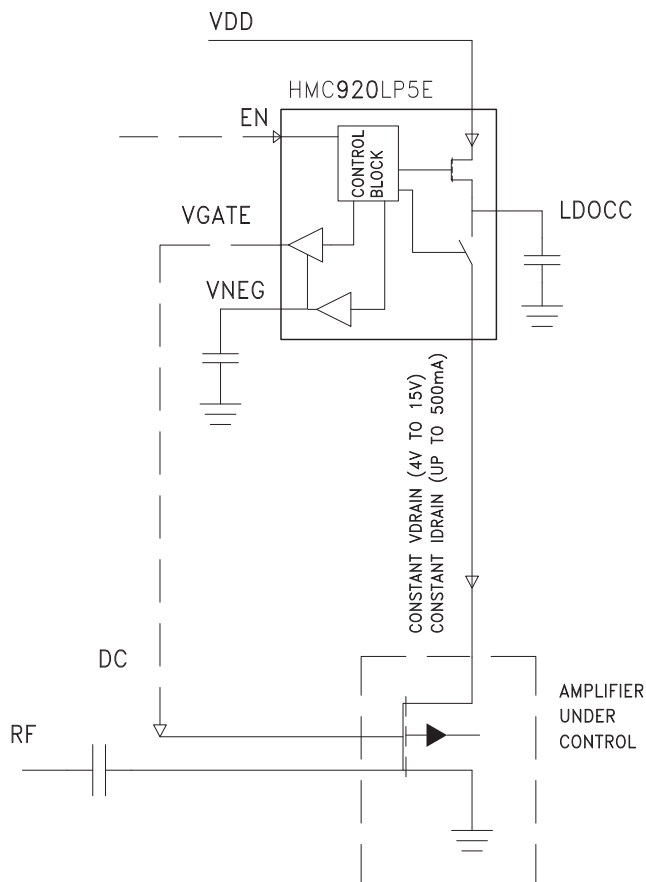



Low Voltage Linear Regulator (VDIG)

The HMC920LP5E requires a low voltage bias rail (3.3V to 5V) for internal circuitry. An internal linear regulator produces a preset 3.5V low-current VDIG output. VDIG powers the internal logic circuitry, oscillator and the control of the negative charge pump. VDIG supplies a maximum of 30mA current and therefore it is recommended for external use only for light loading.

If needed the VDIG output can be adjusted externally through R1 and R3, to a maximum of 5V. To adjust the VDIG value, set R1 to 10kΩ and determine the value of R3 using the equation (1):

$$R3 = \frac{R1}{2.5} \times (VDIG - 2.5) \quad (1)$$

Place the R1 and R3 resistor as close as possible to the VDIG FB pin.

To ensure stable operation of VDIG, bypass VDIG to AGND with a 10μF tantalum capacitor (with R_{ESR} > 200mΩ) under full-load conditions.

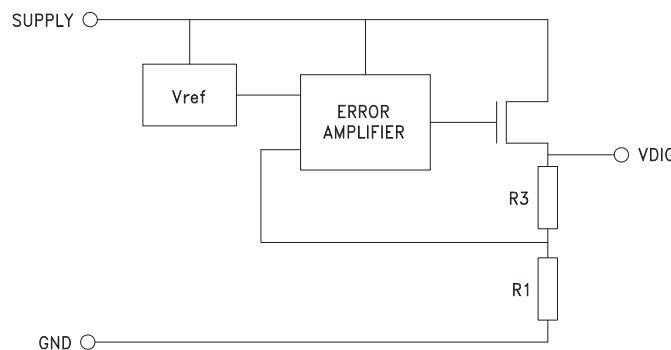

Figure 1. LDOCC Regulator Block Diagram

Reference (BGCAP)

The HMC920LP5E employs two reference voltage generators. The first reference voltage generates 2.5V accurate to ±5% over temperature, supply, and load variations.. This reference voltage generator is used to bias VDIG LDO. A second reference generator generates a stable 2V reference accurate to ±2% over temperature, supply, and load variations. In order to decrease noise, it is recommended to bypass BGCAP to AGND with a 0.1μF or greater ceramic capacitor, as close as possible to the BGCAP pin as possible.



High Voltage Linear Regulator (LDOCC/VDRAIN)

The HMC920LP5E has an adjustable high-voltage, high-current linear regulator (LDOCC) to provide the drain supply rail of the external RF amplifier. The LDOCC output can source up to 500mA loads. The LDOCC output can be adjusted to regulate any voltage level from 3V to 15V through external resistors R8 and R5.

To adjust the LDOCC, set R5 to 10kΩ and determine the value of R8 using the equation (2):

$$R8 = \frac{R5}{2} \times (VDOCC - 2) \quad (2)$$

Place the R8 and R5 as close as possible to the LDOCCFB.

The LDOCC output is connected to the VDRAIN output through an internal MOSFET ($R_{DS-ON} = 0.5\Omega$) switch.

This internal MOSFET is controlled through power-up sequencing which ensures that no voltage is applied to drain of the external amplifier until the gate voltage is pulled down to VNEG(ensuring external amplifier disabled). Connect the external amplifier to the VDRAIN output to use power-up sequencing feature.

Note that there will be a voltage drop from LDOCC to VDRAIN due to finite RDS_ON resistance of the internal switch. To compensate for this voltage drop choose the LDOCC value as shown in equation (3).

$$V_{LDOCC} = V_{DRAIN} + I_{DRAIN} \times 0.5 \quad (3)$$

Where V_{DRAIN} is the supply voltage of the external amplifier and I_{DRAIN} is the desired constant bias current through the external amplifier.

To ensure stable operation of the LDOCC output, bypass LDOCC to AGND with a 10μF tantalum capacitor (with $R_{ESR} > 200m\Omega$).

The HMC920LP5E has power foldback and short circuit protection, refer to the respective section for detailed description of these features.

Negative Voltage Generator (VNEG)

The HMC920LP5E has an internal regulated charge pump block to generate negative voltage (VNEG) required for depletion mode devices. The HMC920LP5E generates -2.5V at the VNEG output in default configuration.

The HMC920LP5E is designed to reject the ripple on the VNEG by isolating VNEG from the VGATE.

The negative voltage is required only for depletion mode devices, and it can be disabled through the VGATEFB and VNEGFB pins. See Table-1 how to set the operation mode.

Enable/Disable (EN)

The active bias control loop is enabled when EN is pulled up to VDIG, and it is disabled when it is pulled down to GND. If EN is left floating HMC920LP5E is enabled through the internal weak pull-up. Note that LDOCC, VDIG and VNEG operation is independent of EN condition. EN signal controls the operation of only VGATE and VDRAIN outputs. When EN pulled down to GND, HMC920LP5E discharges VDRAIN down to GND and it pulls the VGATE down to VNEG. Please see the “Active Bias Control Loop” section for detailed explanation.



Active Bias Control Loop

The HMC920LP5E regulates the bias current (I_{DRAIN}) of the external amplifier through VGATE output connected to the gate of the external amplifier. In this closed loop operation the current passing through the external amplifier is sampled and is used to adjust VGATE to achieve constant quiescent bias through the external amplifier.

The HMC920LP5E continuously compensates for any supply, temperature, process variations and threshold drifts due to aging, without any calibration.

The gate control of the HMC920LP5E can both sink and source current (at least ± 4 mA) to achieve constant bias current over input power variations.

The bias current passing through the external amplifier can be adjusted with R_{SENSE} , where R_{SENSE} is the total resistor ($R4 + R19$) connected from ISENSE to GND. Use the relation given in equation (4) to set the desired bias current through the external amplifier.

$$I_{DRAIN} = \frac{165}{R_{SENSE}} \text{ A} \quad (4)$$

R_{SENSE} adjustment is referenced to the total resistance seen from ALMM (PIN#27) to GND. Connect 5 k Ω resistor from ALMM to GND ($R16 + R15$) to ensure equation (4) holds.

Power Foldback

The HMC920LP5E employs a power foldback protection feature to limit the power consumption on the HMC920LP5E package under excessive loading such as a short circuit from VDRAIN to GND.

HMC920LP5E senses the instantaneous power consumption over the VDRAIN LDO ($P_{SENSE} = (V_{DD} - V_{DRAIN}) \times I_{DRAIN}$), and limits the instantaneous power consumption less than 4.5W. This is achieved by decreasing VDRAIN voltage and I_{DRAIN} current simultaneously.

The advantage of the power foldback protection feature over a hard current limit is safe operation with higher user flexibility.

The following plots present the power foldback characteristic over Vdd.

Power Foldback VDRAIN vs. IDRAIN over Vdd

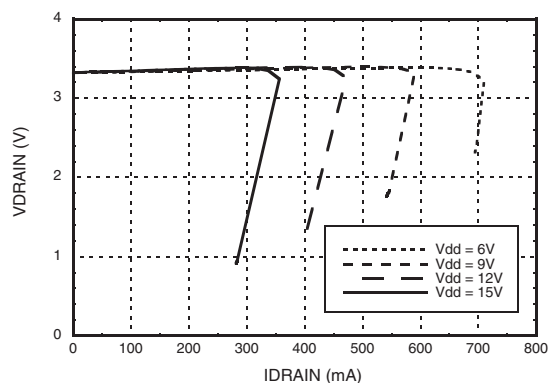

Power Foldback Delivered Power vs. IDRAIN Over Vdd

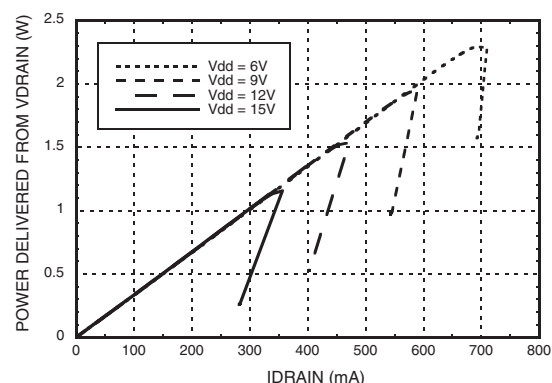



Power Dissipated on HMC920LP5E vs. IDRAIN Over Vdd

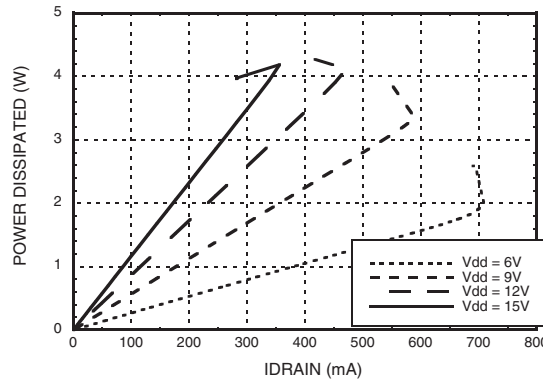

Short Circuit Protection

The pass transistor in every LDO is in series with the load, and a large amount of current will flow through the regulator during a short condition when no precaution circuitry is included in the system. The HMC920LP5E limits the current through the pass transistor to less than 900mA, and this current limit acts as the secondary short circuit protection to the power foldback feature. During a VDRAIN-GND short circuit HMC920LP5E also pulls down the VGATE to the lowest voltage supply VNEG, and disables the external amplifier completely for safety.

HMC920LP5E continuously checks the following pins for short conditions and disables the system when a short to ground is detected.

- LDOCC
- VDRAIN
- VNEG (in depletion mode)
- FIXBIAS

Over/Under Current Alarm

The HMC920LP5E provides over and under current alarm indicator CURALM (pin#8) signal. The CURALM is pulled up to VDIG when the IDRAIN current exceeds $\pm 25\%$ of IDRAIN regulation target value.

The condition of CURALM signal does not effect the operation of HMC920LP5E, it is provided only for monitoring purposes.

The CURALM signal is activated if the low and high current duration is longer than a certain threshold. This duration can be adjusted through the external resistor R26 with equation 5. Figure-2 presents a behavioral sketch how the CURALM indicator signal acts under various IDRAIN conditions.

$$T_{wait} = R26 \times 5.1 \times 10^{-4} + 3 \quad (5)$$

where T_{wait} is in micro seconds. Changing R26 from 10 kOhms to 10 Megohms, T_{wait} can be adjusted from 8.1 usec to 51 msec.

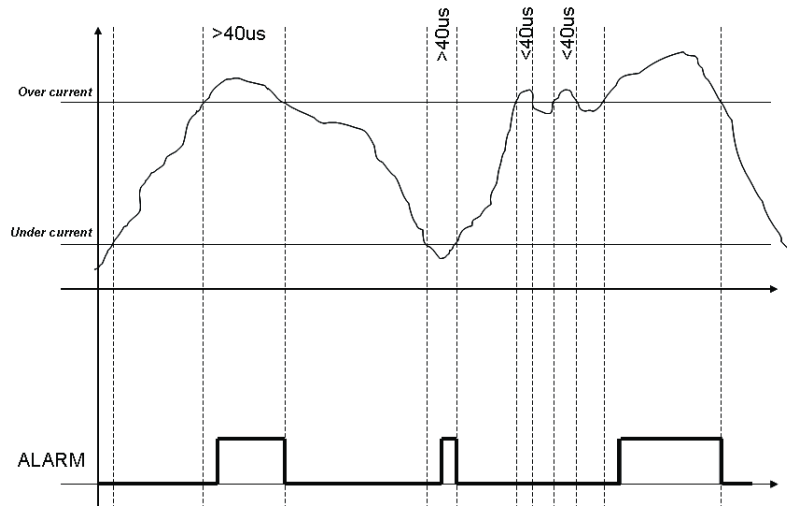

Figure 2. Current Alarm Behavior

Vdd Under-Voltage Alarm

The HMC920LP5E provides a low Vdd indicator signal (VddALM pin#31) when the Vdd supply voltage is lower than an user adjustable threshold value. VddALM pin pulled up to VDIG when the Vdd voltage is lower than the adjusted VddTHR value. To adjust the Vdd under-voltage alarm threshold set R6 (the resistance from VddCHK to AGND) according to the relation provided in (6).

$$R6 = \frac{150k\Omega}{\left(3 \times \frac{VddTHR}{0.88} - 13\right)} \quad (6)$$

Power-up and Enable Sequencing

To ensure the safety of the external amplifier the HMC920LP5E provides a certain power-up sequence for enabling active bias control loop. During start-up VDRAIN is kept at GND while VGATE is taken to the most negative supply available (VGATE=VNEG). This ensures that external amplifier is completely turned-off before VDRAIN is applied. When EN signal is received VDRAIN is applied and the active bias loop is enabled. The final phase of the power-up sequence is completed by increasing the VGATE linearly until the set IDRAIN value is achieved.

For power-down and disabling the same sequencing is applied in the reverse order.

Daisy-Chain Operation

HMC920LP5E produces a trigger out signal (TRGOUT pin#24) when the external amplifier achieves a stable bias current (IDRAIN).. This trigger signal can be used to enable additional HMC920LP5E chips in a chain of amplifiers. The triggering sequence can be routed in anyway, from input to output, or from output to input depending on the use. Figure-3 presents a sample use of three HMC920LP5Es in an amplifier chain. Please note that, only one of the HMC920LP5E is used to generate the negative voltage and the remaining HMC920LP5E is set to receive external negative voltages (which is provided from the master HMC920LP5E). Generating negative voltage only with single HMC920LP5E reduces the number of the components in the system, and decreases the over all current consumption slightly, compared to each bias controller generating its own negative voltage.

To ensure proper start-up, the system enable signal should ne applied to the chip that has the negative voltage generator.

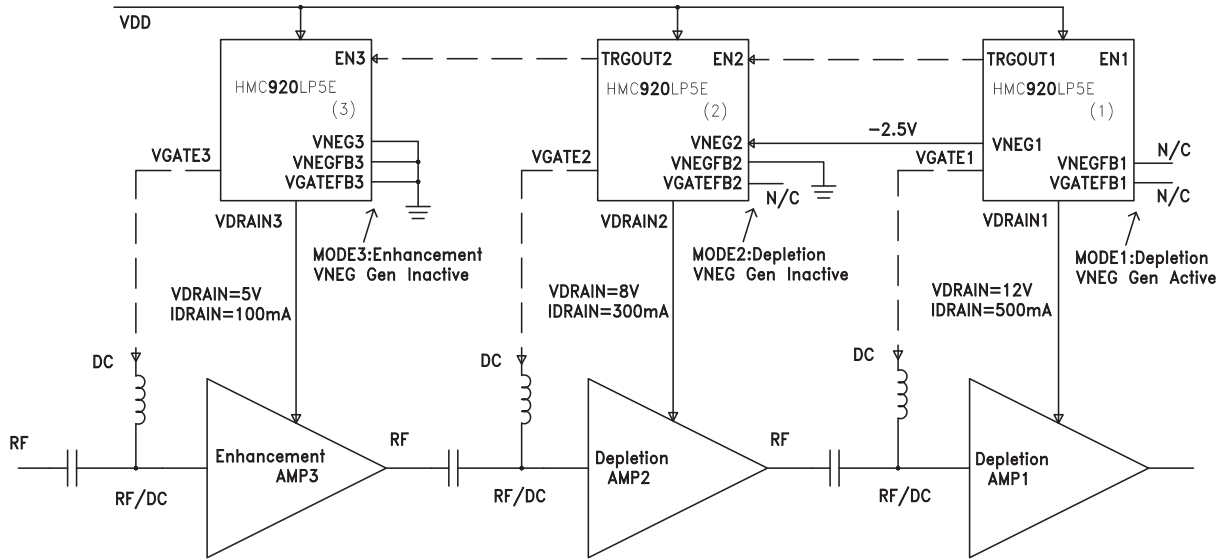

Figure 3. Daisy Chain Operation

Operation Modes

HMC920LP5E can be configured to bias both enhancement and depletion mode external amplifiers. The mode of operation can be selected by setting two pins (VNEGFB, VGATEFB) as tabulated in Table-1. The connection to the VNEGIN should be adjusted accordingly.

In order not to bias external amplifier in a wrong region, please make sure that the correct mode of operation is selected before powering up HMC920LP5E.

HMC920LP5E does not allow the internal negative voltage generator to work if an enhancement mode is selected. Therefore, if VNEGFB is left floating while VGATEFB is grounded, HMC920LP5E will stay in standby mode.

Please note that the external negative voltage should be between -2.5V to -3.5V for HMC920LP5E to operate.

Table 1. Mode Selection

	VNEGFB	VGATEFB	VNEGIN	Description
MODE1 (Depletion/Master Mode)	FLOAT	FLOAT	Connected to VNEGOUT	Depletion mode transistor. Internal negative voltage generator is active and generates -2.5V. Sample application schematic given shown in Fig.4a.
MODE2 (Depletion/Slave Mode)	GND	FLOAT	Connected to External VSS	Depletion mode transistor. Internal negative voltage generator is disabled. An external negative voltage less than -2.3V should be connected to VNEGIN. Sample application schematic given shown in Fig.4b.
---	FLOAT	GND	N/A	Not allowed. HMC920LP5E stays in standby.
MODE3 (Enhancement Mode)	GND	GND	Connected to GND	Enhancement mode transistor. Internal negative voltage generator is disabled. Sample application schematic given shown in Fig.5.



Figure 4a: Depletion/Master Mode Amplifier Typical Application Circuit (Mode 1)

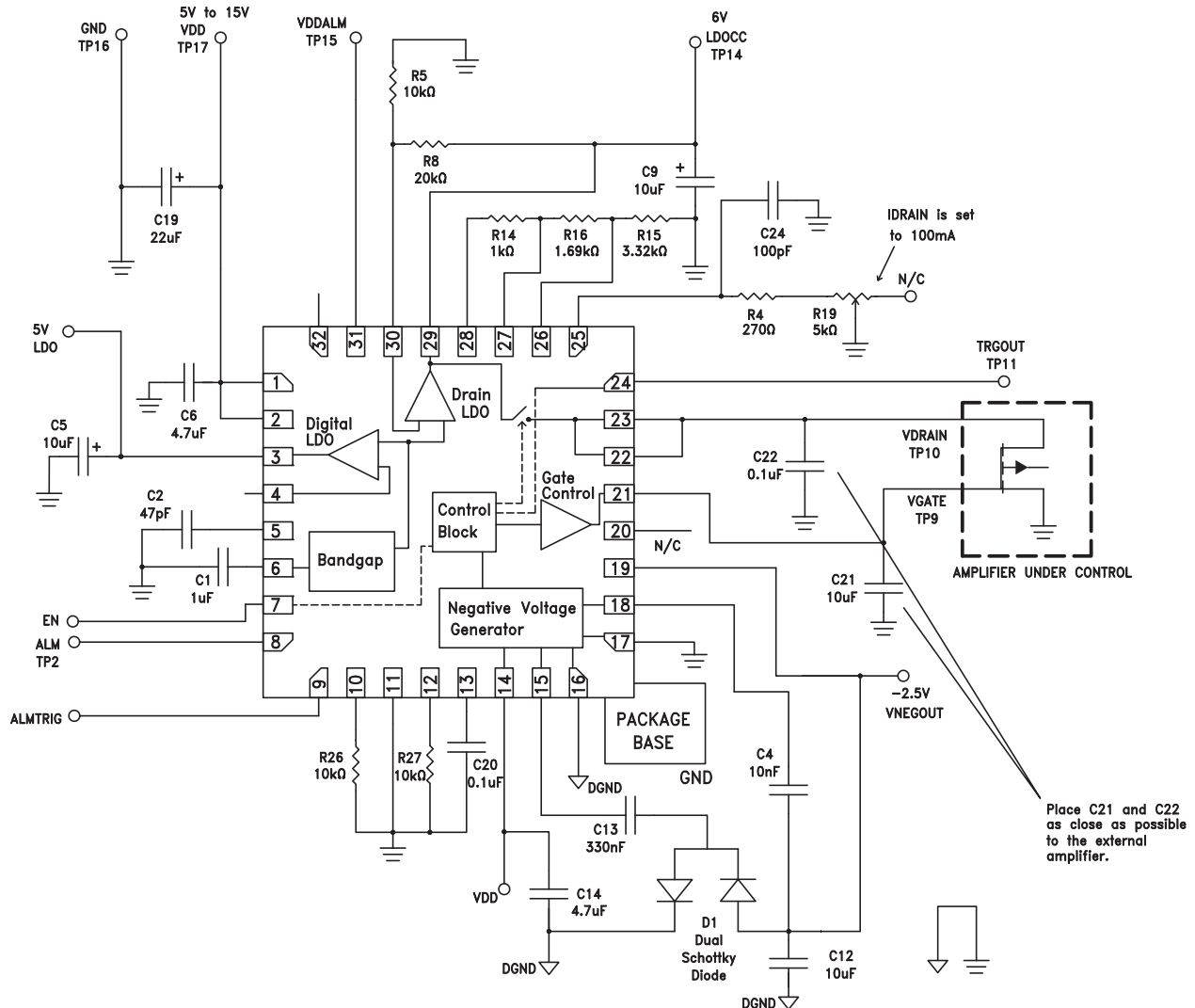

Figure 4b: Depletion/Slave Mode Amplifier Typical Application Circuit (Mode 2)

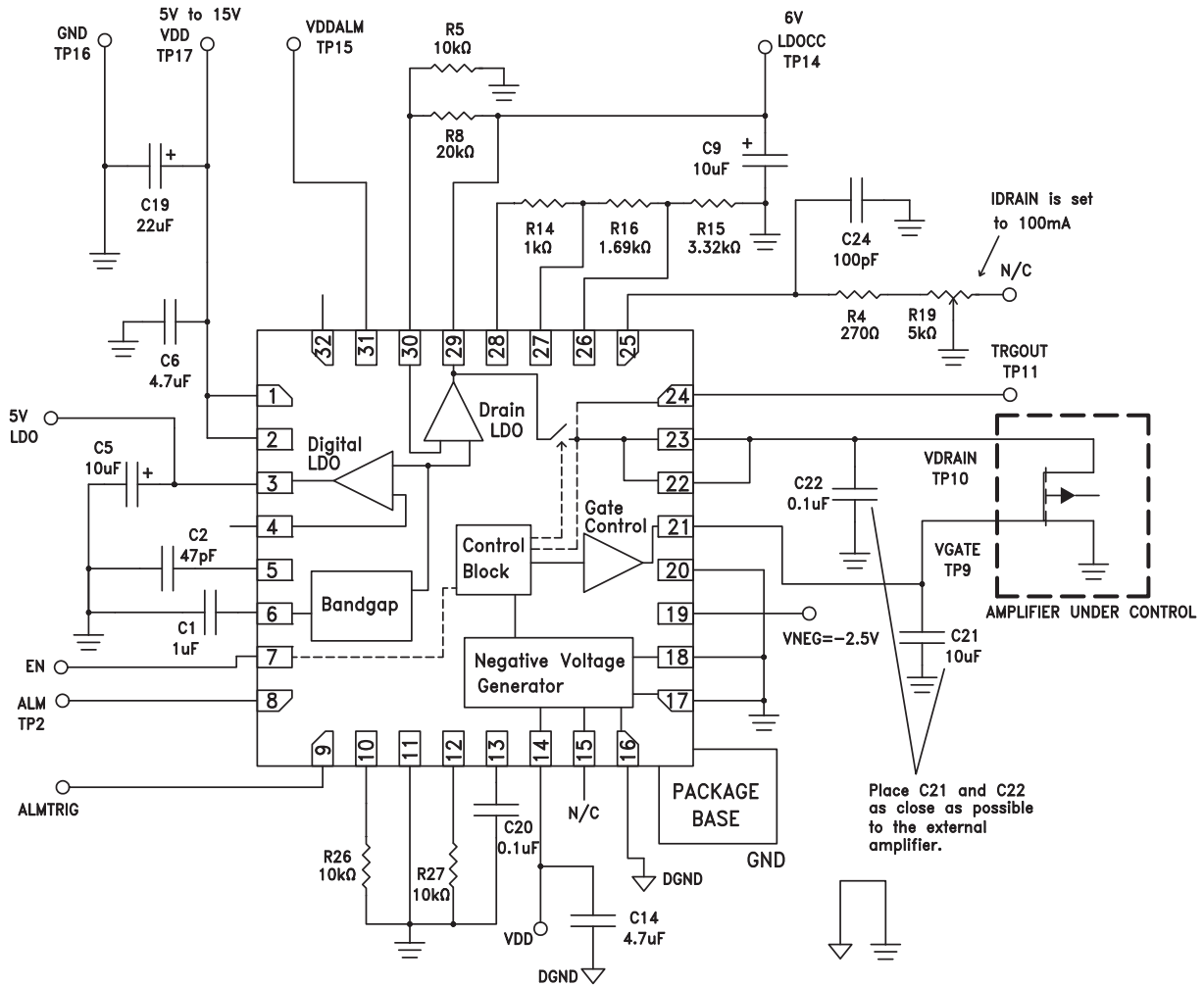
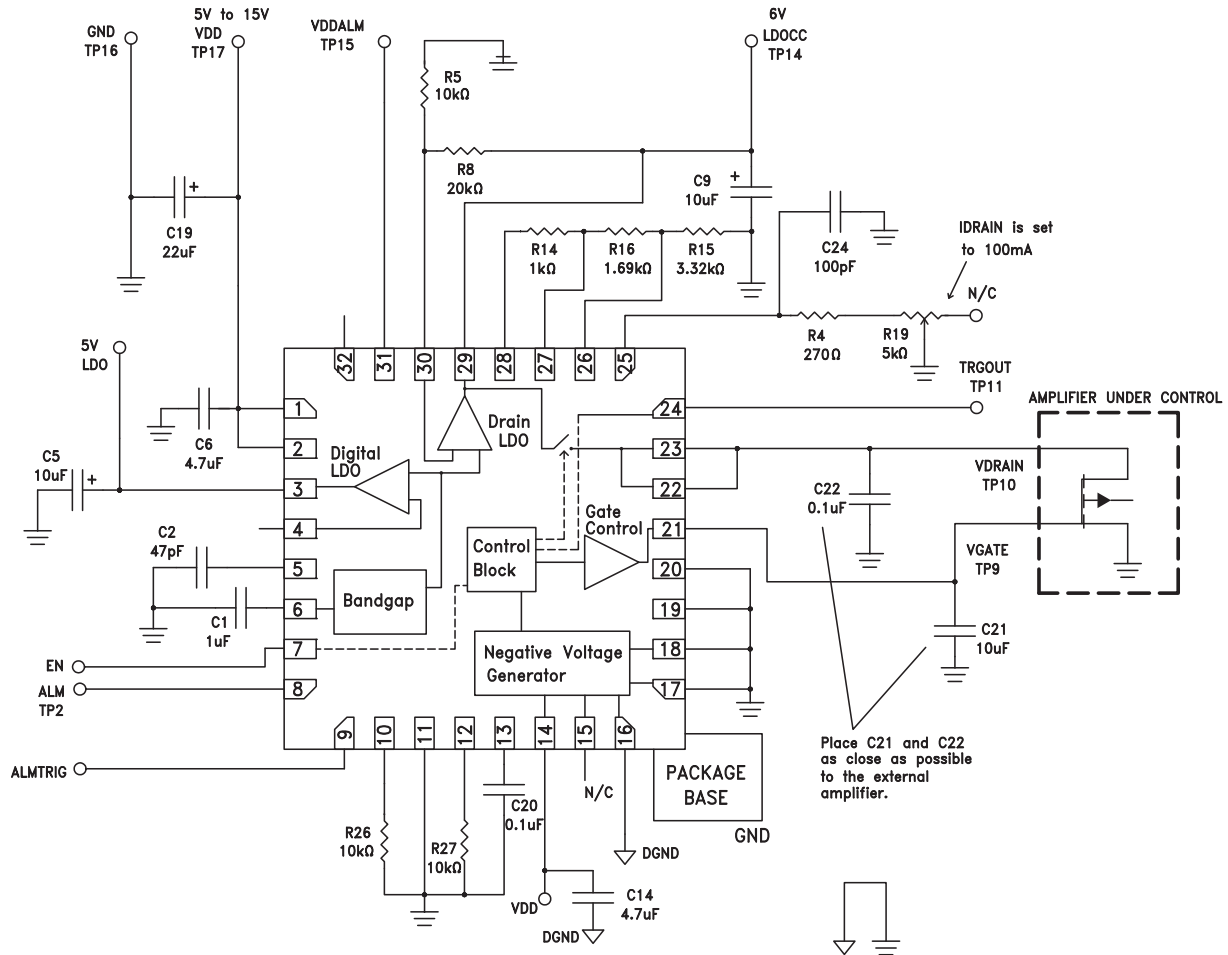



Figure 5: Enhancement Mode Amplifier Typical Application Circuit (Mode 3)



13

DC POWER MANAGEMENT - SMT



Table 2 - The List of Bias Settings for Various Hittite Amplifiers

Hittite Part Number	VDRAIN (V)	IDRAIN (mA)	LDOCC (V)	RSENSE (kΩ)	R8 (kΩ)
LNAs					
HMC609LC4	6	170	6.085	0.98	20.43
HMC594LC3B	6	100	6.05	1.66	20.25
HMC753LP4	5	55	5.0275	3.02	15.14
HMC490LP5	5	200	5.1	0.83	15.5
HMC504LC4B	4	90	4.045	1.84	10.23
HMC-ALH140	4	60	4.03	2.77	10.15
HMC-ALH244	4	45	4.0225	3.69	10.11
HMC772LC4	4	45	4.0225	3.69	10.11
HMC752LC4	3	70	3.035	2.37	5.18
Gain Blocks & Drivers					
HMC635LC4	5	280	5.14	0.59	15.7
HMC-AUH256	5	295	5.1475	0.56	15.74
Linear & Power					
HMC757	7	395	7.1975	0.42	25.99
HMC441LM1	5	90	5.045	1.84	15.23
HMC442LM1 / HMC442LC3B	5	85	5.0425	1.95	15.21
HMC-ABH209	5	80	5.04	2.08	15.2
HMC-APH403	5	475	5.2375	0.35	16.19
HMC-APH596	5	400	5.2	0.42	16
HMC608LC4	5	310	5.155	0.54	15.78
HMC498LC4	5	250	5.125	0.66	15.63
HMC-ABH241	5	220	5.11	0.75	15.55
HMC499LC4	5	200	5.1	0.83	15.5
HMC-APH196	4.5	400	4.7	0.42	13.5
HMC-APH633	4	240	4.12	0.69	10.6
HMC-AUH317	4	160	4.08	1.04	10.4
HMC-AUH318	4	160	4.08	1.04	10.4
HMC-AUH320	4	130	4.065	1.28	10.33
Wideband (Distributed)					
HMC637LP5	12	400	12.2	1.16	35.19
HMC619LP5	12	300	12.15	1.55	35
HMC559	10	400	10.2	1.16	27.78
HMC562	8	80	8.04	5.81	19.78
HMC460LC5	8	75	8.0375	6.2	19.77
HMC659LC5	8	300	8.15	1.55	20.19
HMC464LP5	8	290	8.145	1.6	20.17
HMC459	8	290	8.145	1.6	20.17
HMC465LP5	8	160	8.08	2.91	19.93
HMC462LP5	5	66	5.033	7.05	8.64
HMC463LP5	5	60	5.03	7.75	8.63
HMC635	5	280	5.14	1.66	9.04
HMC634LC4	5	180	5.09	2.58	8.85
HMC633LC4	5	180	5.09	2.58	8.85

For price, delivery, and to place orders, please contact Hittite Microwave Corporation:
 20 Alpha Road, Chelmsford, MA 01824 Phone: 978-250-3343 Fax: 978-250-3373
 Order On-line at www.hittite.com

